



GEEPLUS

Tubular Solenoid size 133

Device drawn in energised condition

Available plunger options:

pull (-Lx) / push (-Hx)

Life Expectancy (cycles):

>2M (-L, ;-H),

>5M (-LE, ;-HE),

>10M (-LL, ;-HL)

Available mechanical options:

M: metric thread

F: SAE thread

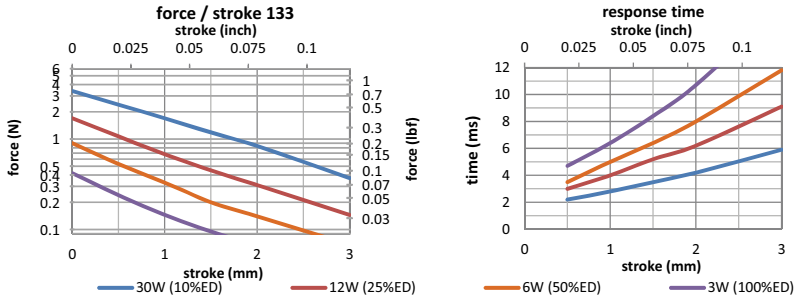
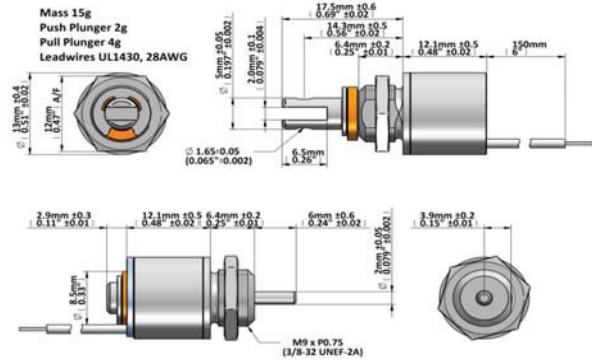

Data at 20°C, device connected to heatsink 50x50x3mm aluminum

duty cycle = $\frac{\text{"on" time}}{\text{"on" time} + \text{"off" time}} \times 100\%$		100% cont.	50% or less	25% or less	10% or less	
Max. "on" time in seconds		∞	38	4	1	
watts at 20°C		3	6	12	30	
ampere-turns at 20°		232	330	465	735	
AWG no.	resistance	number of turns	volts DC			
	$\Omega \pm 10\%$ (at 20°C)					
29	1.0	141	1.7	2.4	3.4	5.0
30	1.6	175	2.0	3.0	4.3	7.0
31	2.5	217	2.7	3.8	5.4	9.0
32	3.9	268	3.4	4.8	7.0	11
33	6.1	332	4.3	6.0	9.0	14
34	9.5	410	5.4	7.7	11	17
35	14.8	506	6.8	10	14	22
36	23.0	625	8.5	12	17	27
37	35.8	770	10.8	15	22	34
38	55.7	949	13.6	19	27	43
39	86.5	1169	17.0	24	34	54
40	134	1440	21.6	31	43	68
41	209	1774	27.0	39	55	87
42	324	2184	34.5	49	69	109
43	503	2688	43.5	62	87	137

Insulation Resistance >100MΩ, 500VDC Megger
Class E (120°C) insulation class

Dielectric Strength 1000VAC, 50/60Hz, 1 minute

Geepus reserves the right to change specifications without notice

www.geeplus.biz e-mail: info@geeplus.biz