

[Open frame solenoid]



	SK Series	TO Series	RD Series
Price	Most Costly	Cost-effective in high volume	Cost-effective in small volume
Lead-time	8-10 wks	8-10 wks	<3-4 wks ex factory for quantities <10k
Reliability	>500k cycles	>500k cycles	>500k cycles
Quality	Exceptional	Good	Good
Customization	Available for orders >500 pcs	Available for orders >5k pcs	Available for orders >500 pcs

SK Series Open Frame Solenoids: (See Geeplus 'Solenoid Design Manual')

The SK series are built on the same production lines and subject to the same in-process checks as our rotary, push-pull and other high performance solenoids. Quality Control is much more rigorous than is usually applied to the production of open frame solenoids. Maximum performance is maintained by using high permeable steel while good quality manufacturing technology is adopted to minimize air gaps in the metal frame assembly. High quality coil winding techniques ensure all allowable space along the frame is occupied by the coil winding. Our SK series should be used where the open frame solution meets performance needs but where reliable operation is critical.

TO Series Open Frame Solenoids:

Your first choice for high volume applications will be our range of TO series open frame solenoids. This range of high performance open frame solenoids are intended to provide a cost effective solution where the need for a standard design in coil and frame, at a cost effective rate, are essential. The TO series already provides significant solutions in the locking, latching and paper sorting industries where the emphasis is on production line manufacture. In addition, for very high volume applications, Geeplus manufactures in China for our TO series solenoids while tooling and quality control are maintained in Japan.

[Open frame solenoid] (All dimensions are in mm, unless otherwise stated)

RD Series Open Frame Solenoids:

This particular range of open frame solenoids have been introduced to offer flexible production with fast turnaround. With the emphasis on 'Rapid Delivery', the production cell uses flexible machinery and quick-change fixtures to permit rapid set up times.

The RD series range of solenoids can also be considered for larger orders requiring a fast delivery time. Modified parts as well as standard production quantities are normally turned around in 3-4 weeks ex-factory (providing tooling already exists for the modifications). This service is aimed at customers requiring shorter lead times.

All three series of open frame solenoids can be modified to suit specific applications. Modification to the mechanical configurations (e.g. incorporation of pushrod, return spring, adapted plunger attachment), to electrical construction (e.g. coil winding, addition of specific connectors), may be customised to attain explicit force-stroke characteristics required for a particular application.

T0-0420

Voltage (V)	Resistance (Ω)	Current (mA)
6	32.7	183
12	131	91.7
24	524	45.8

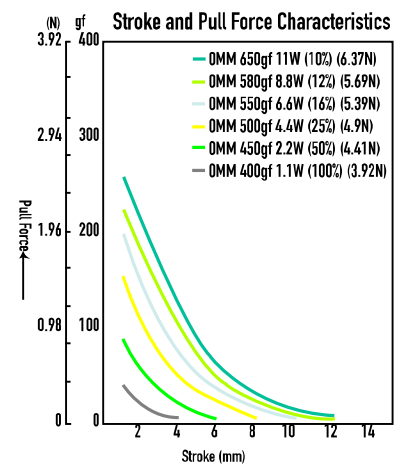
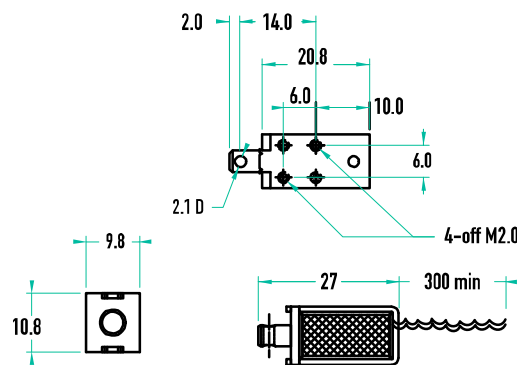

[Open frame solenoid]

RD-A420

Voltage (V)	Resistance (Ω)	Current (mA)
6	32.7	183
12	131	92
24	524	46

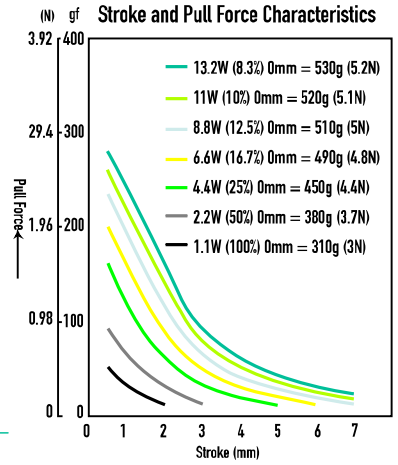
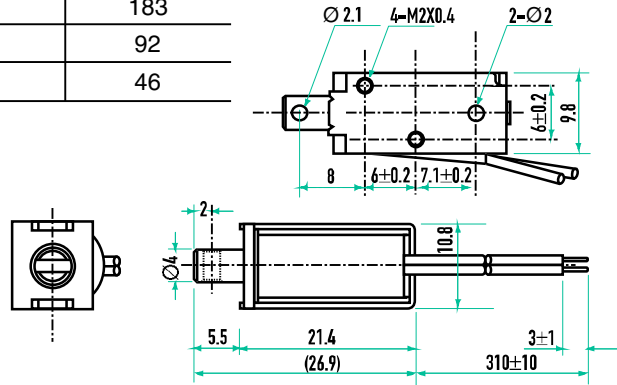

RD-B425

Voltage (V)	Resistance (Ω)	Current (mA)
6	24	250
12	96	125
24	384	63

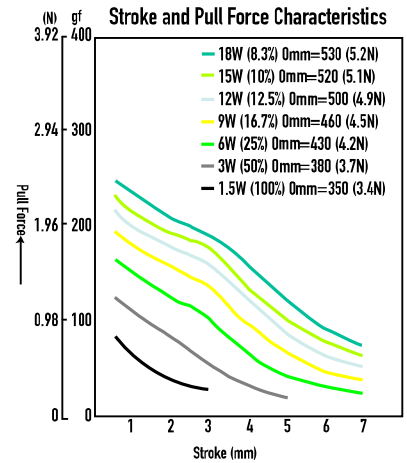
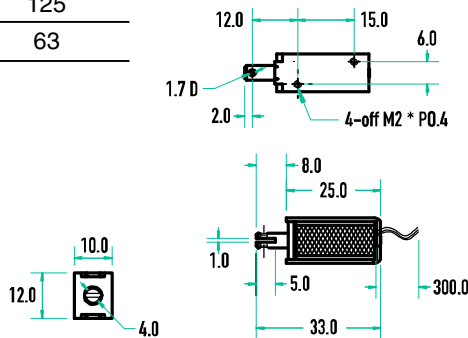

RD-A520

Voltage (V)	Resistance (Ω)	Current (mA)
6	24	250
12	96	125
24	384	63

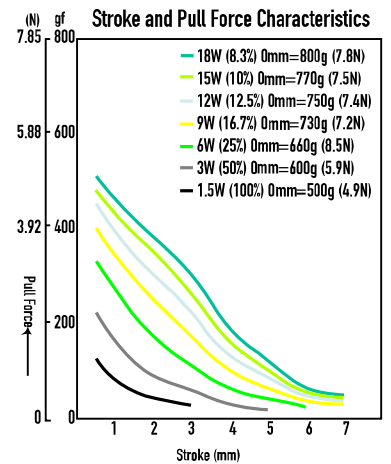
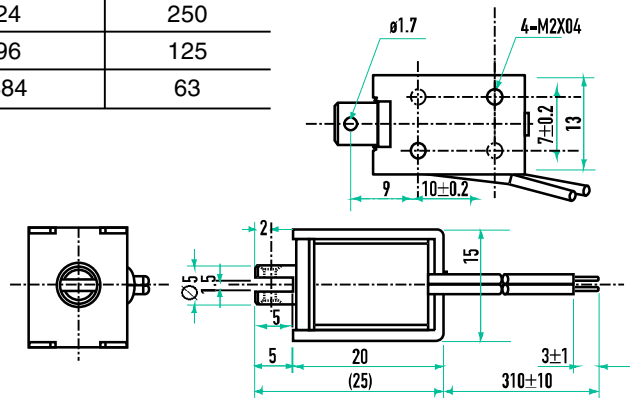

[Open frame solenoid]

RD-U617

Voltage (V)	Resistance (Ω)	Current (mA)
6	20	300
12	80	150
24	320	75

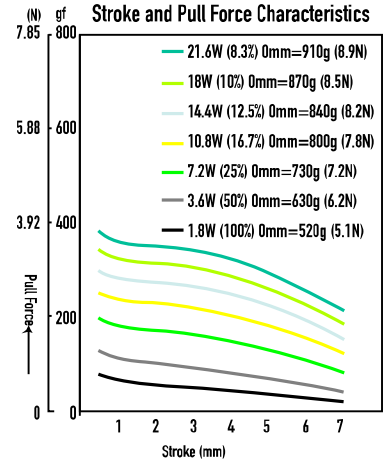
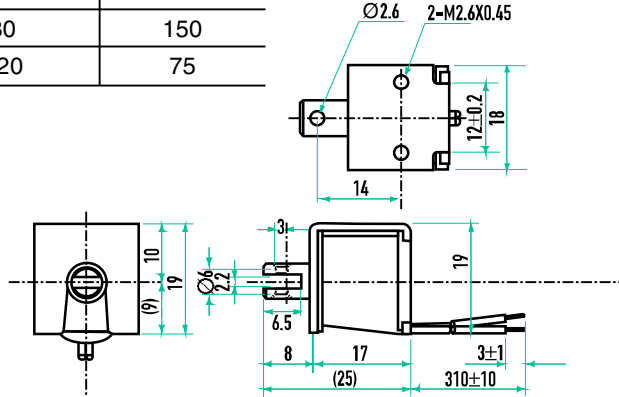

RD-A625

Voltage (V)	Resistance (Ω)	Current (mA)
6	17.1	351
12	68.6	175
24	27.4	88

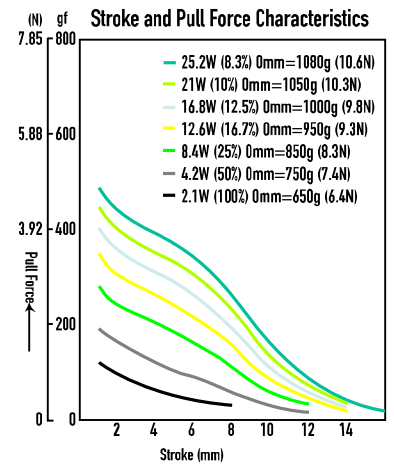
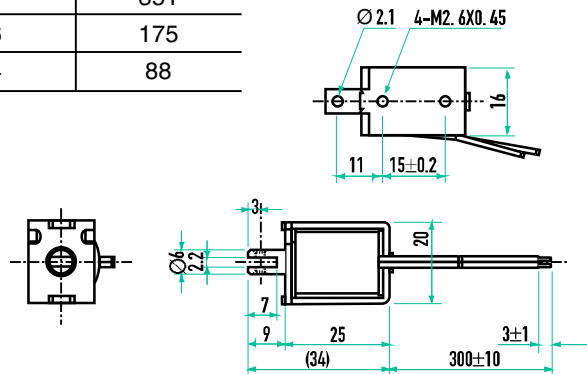

T0-0626

Voltage (V)	Resistance (Ω)	Current (mA)
6	17.2	348.8
12	69	174
24	274	87.6

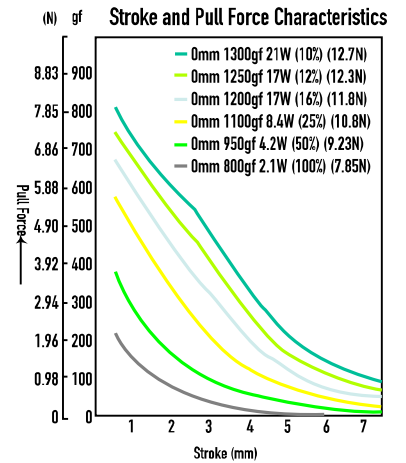
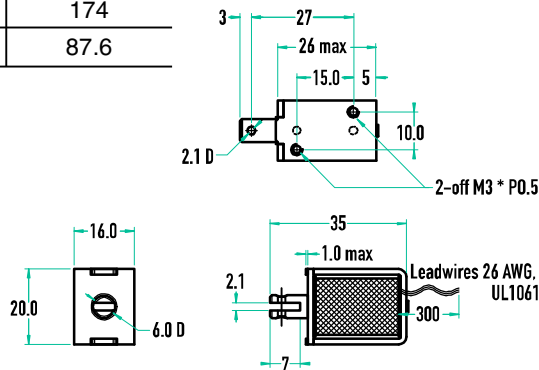

[Open frame solenoid]

RD-A628

Voltage (V)	Resistance (Ω)	Current (mA)
6	15	400
12	60	200
24	240	100

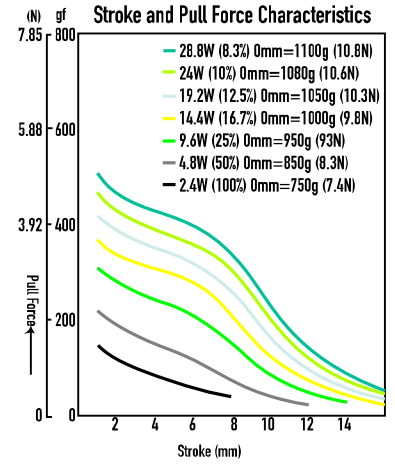
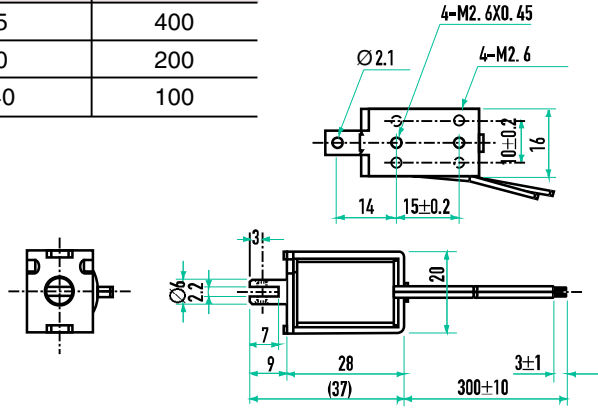

RD-B630

Voltage (V)	Resistance (Ω)	Current (mA)
6	16.4	366
12	65.4	183
24	264	92

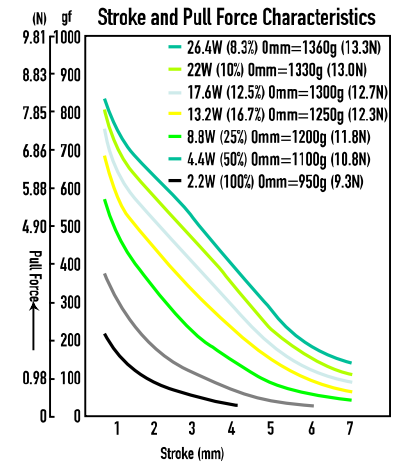
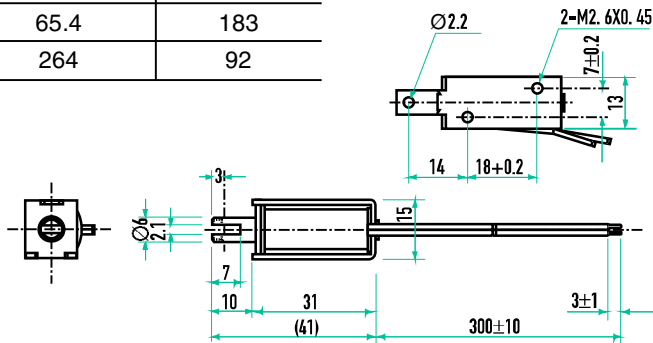

RD-U640

Voltage (V)	Resistance (Ω)	Current (mA)
6	15	400
12	60	200
24	240	100

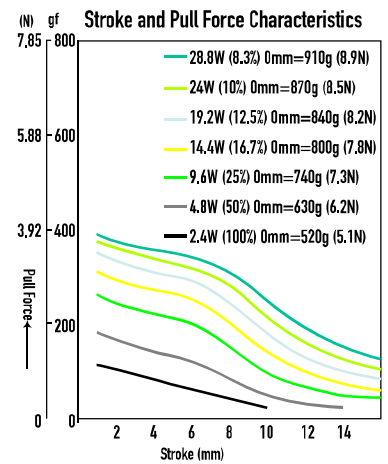
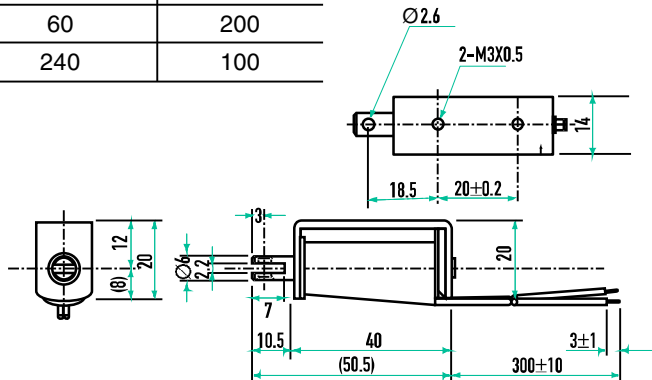

[Open frame solenoid]

RD-A730

Voltage (V)	Resistance (Ω)	Current (mA)
6	16.4	366
12	65.5	183
24	262	92

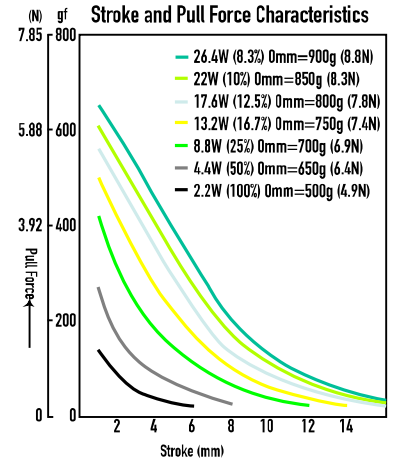
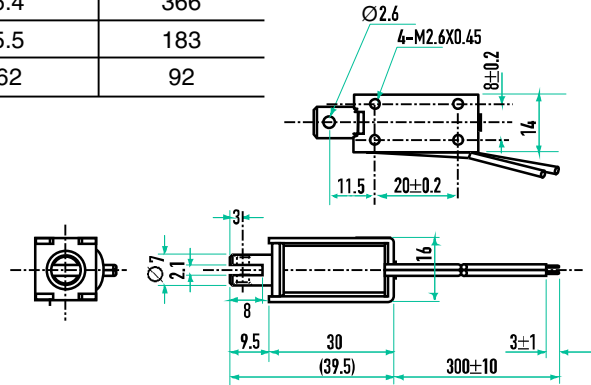

T0-0836

Voltage (V)	Resistance (Ω)	Current (mA)
6	10.6	566
12	42	283
24	169	142
80	1880	42.5
100	2940	34

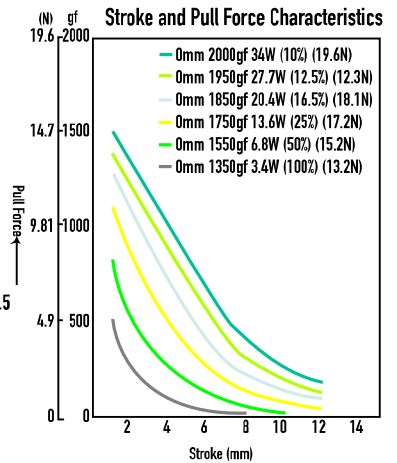
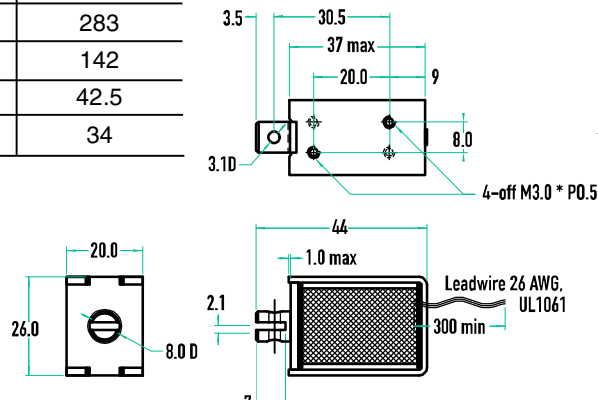

RD-A840

Voltage (V)	Resistance (Ω)	Current (mA)
6	10.6	566
12	42.4	283
24	169	142

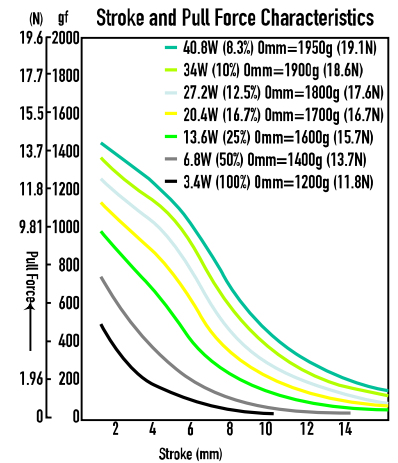
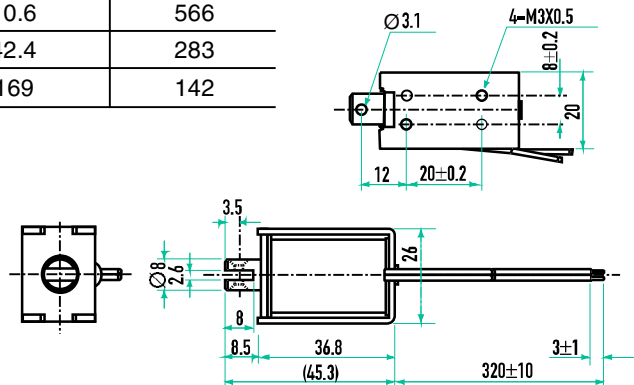

[Open frame solenoid]

RD-B840

Voltage (V)	Resistance (Ω)	Current (mA)
6	11.3	531
12	45	267
24	180	133
80	2000	40
100	3125	32

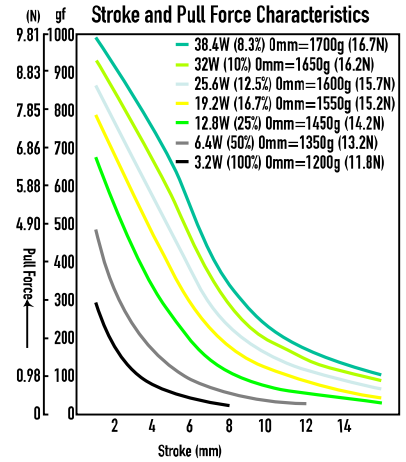
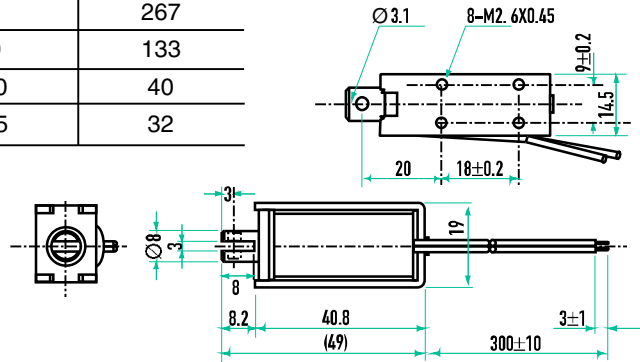

T0-0841

Voltage (V)	Resistance (Ω)	Current (mA)
6	13.8	435
12	55.4	217
24	221	109
80	2461	33
100	3846	26

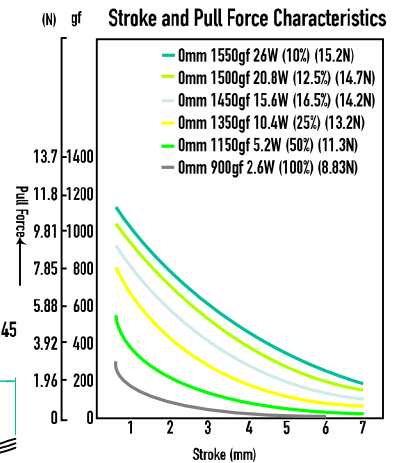
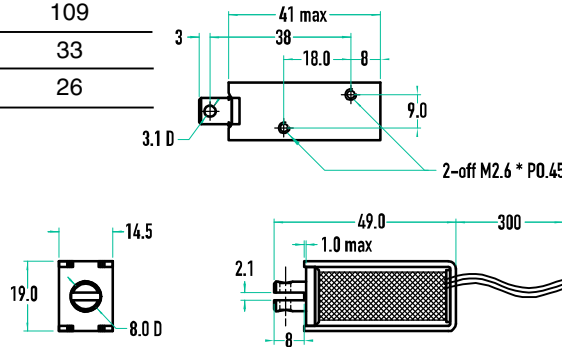

RD-A940

Voltage (V)	Resistance (Ω)	Current (mA)
6	10.3	583
12	41.1	292
24	165	145
80	1829	44
100	2857	35

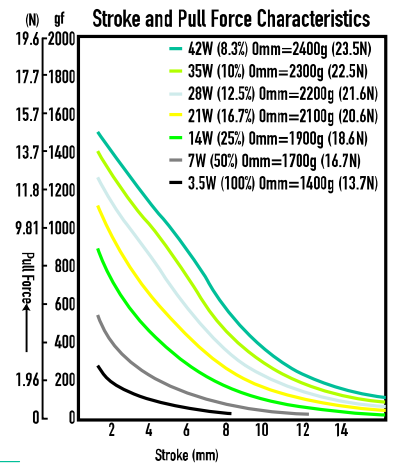
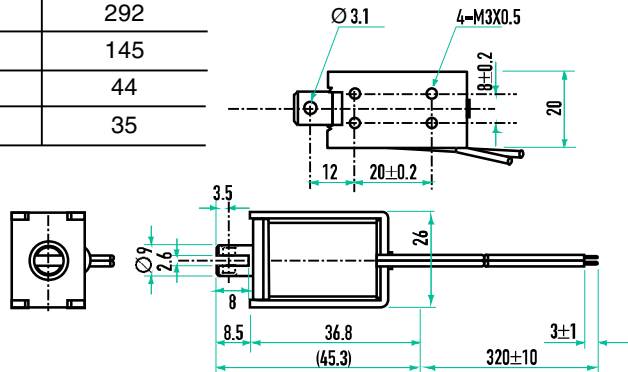

[Open frame solenoid]

RD-B945

Voltage (V)	Resistance (Ω)	Current (mA)
6	8.4	714
12	33.5	358
24	134	179
80	1488	54
100	2326	43

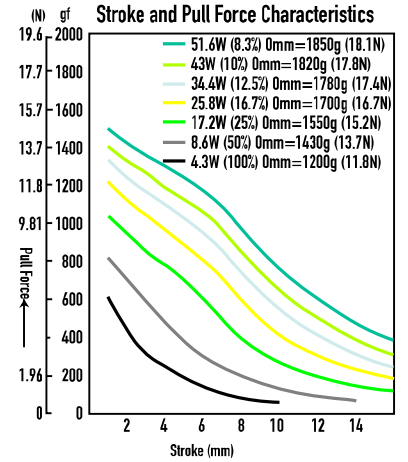
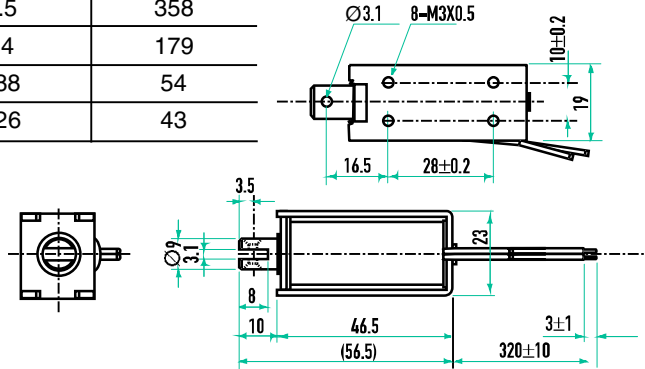

RD-A1040

Voltage (V)	Resistance (Ω)	Current (mA)
6	8	750
12	32	375
24	128	188
80	1422	56
100	2222	45

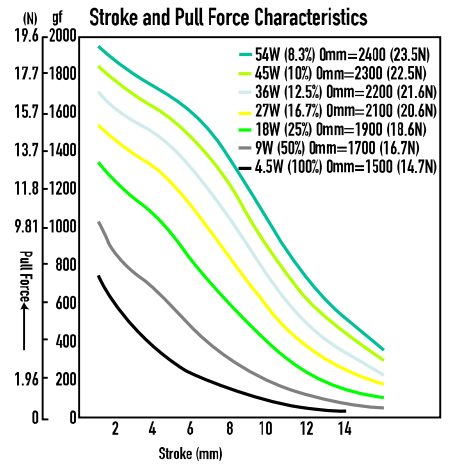
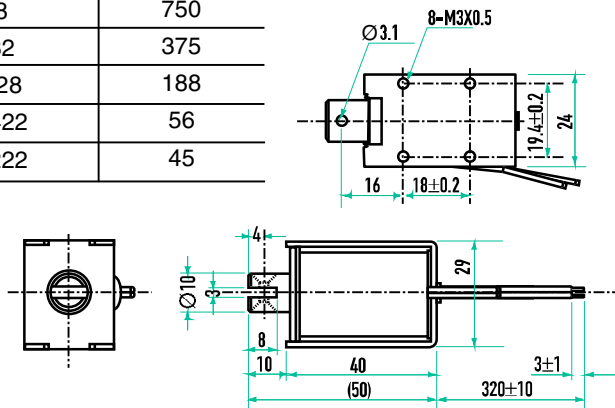

RD-A1053

Voltage (V)	Resistance (Ω)	Current (mA)
6	6.7	896
12	26.7	449
24	107	224
80	1185	67
100	1852	54

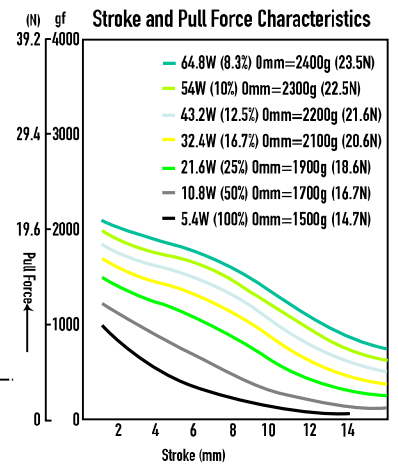
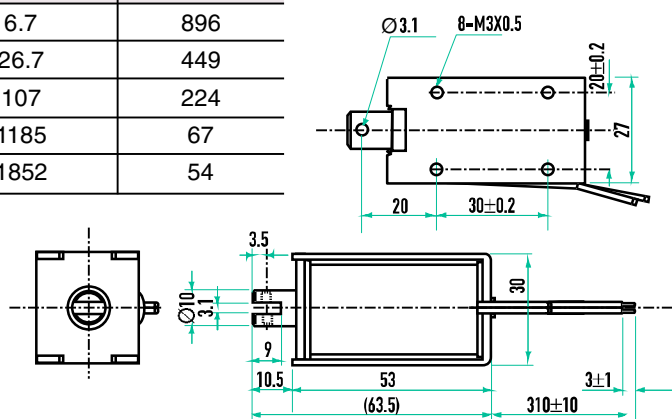

[Open frame solenoid]

T0-1240

Voltage (V)	Resistance (Ω)	Current (mA)
6	8	750
12	32	375
24	128	187
80	1422	56
100	2222	45

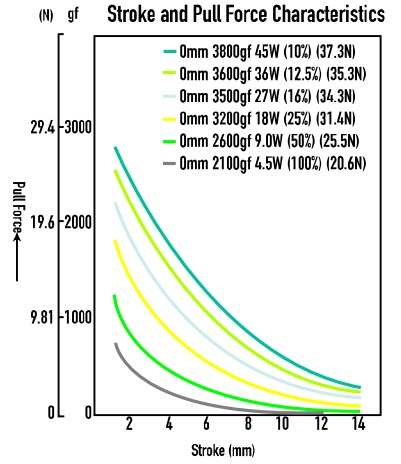
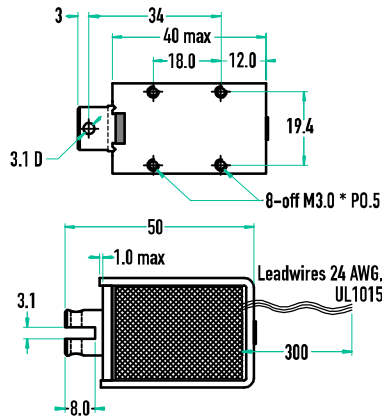
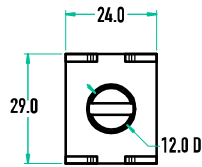

RD-A1250

Voltage (V)	Resistance (Ω)	Current (mA)
6	4.8	1250
12	19.2	625
24	76.8	313
80	853	94
100	1333	75

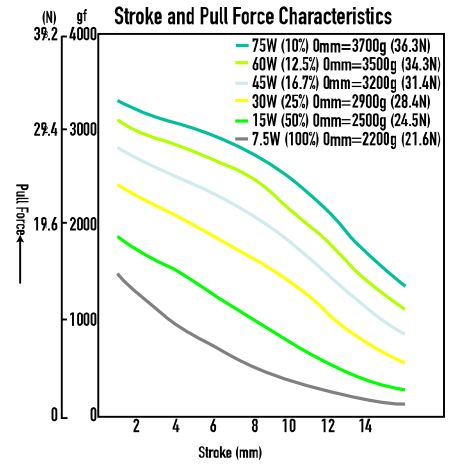
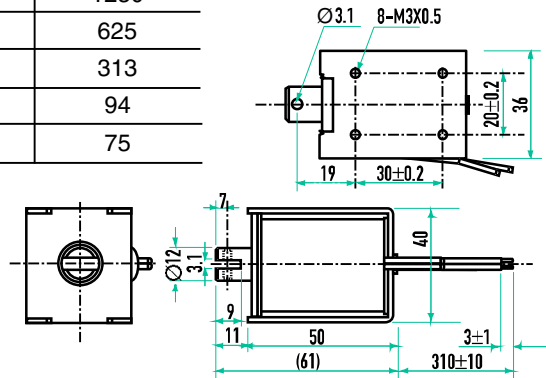

RD-A1264

Voltage (V)	Resistance (Ω)	Current (mA)
6	4.8	1250
12	19.2	625
24	76.8	313
80	853	94
100	1333	75

